

Standard version:

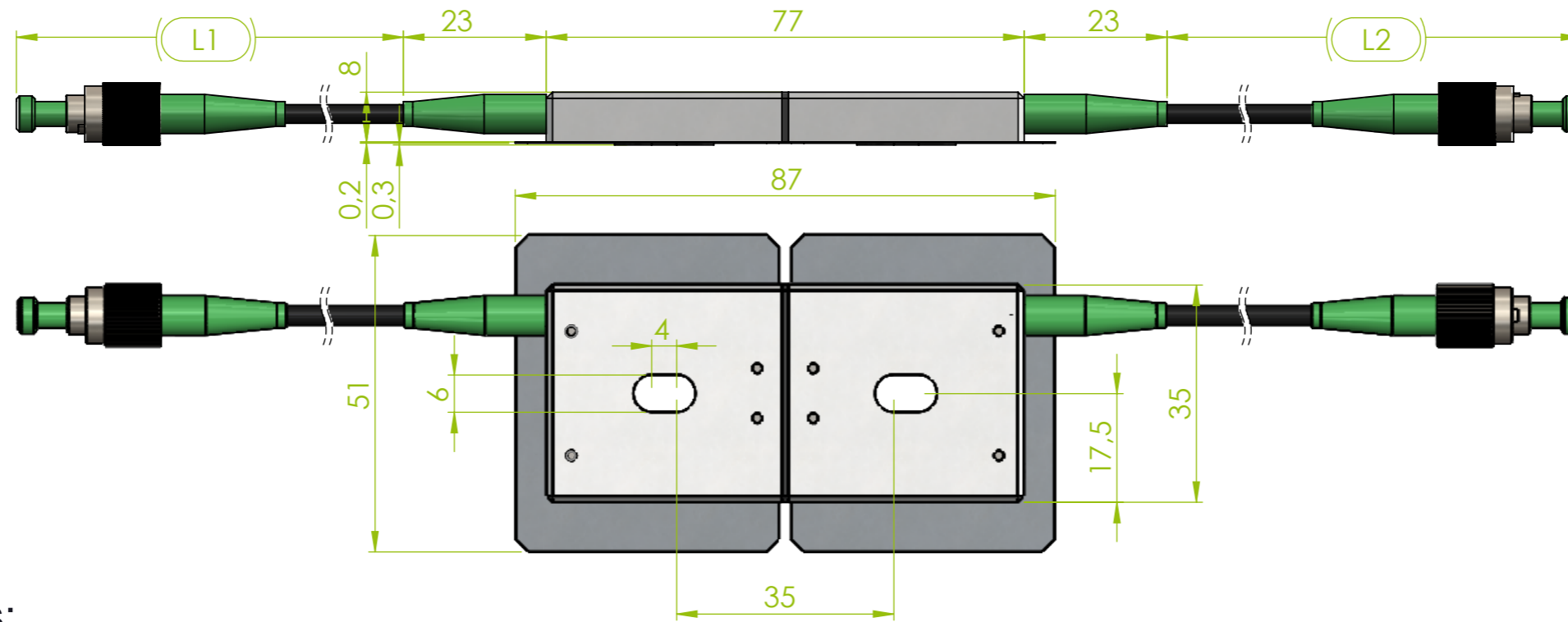

Optional accessories:

- PST-02 Pre-strain setup tool:

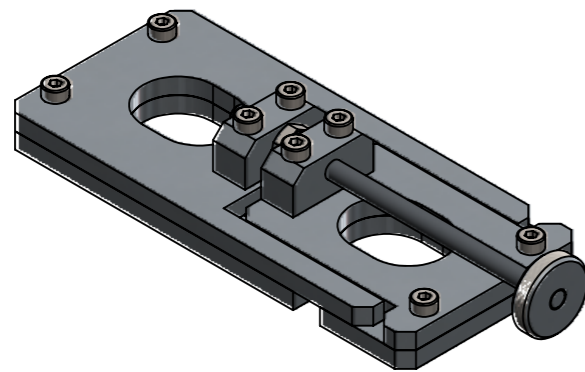

- LCP-03 Longer Dyneema cable pigtail with 1x WSP-02 (Watertight Splice Protection) and with 1x WCP-01 Watertight Connector Protection 1x FC/APC IP67:

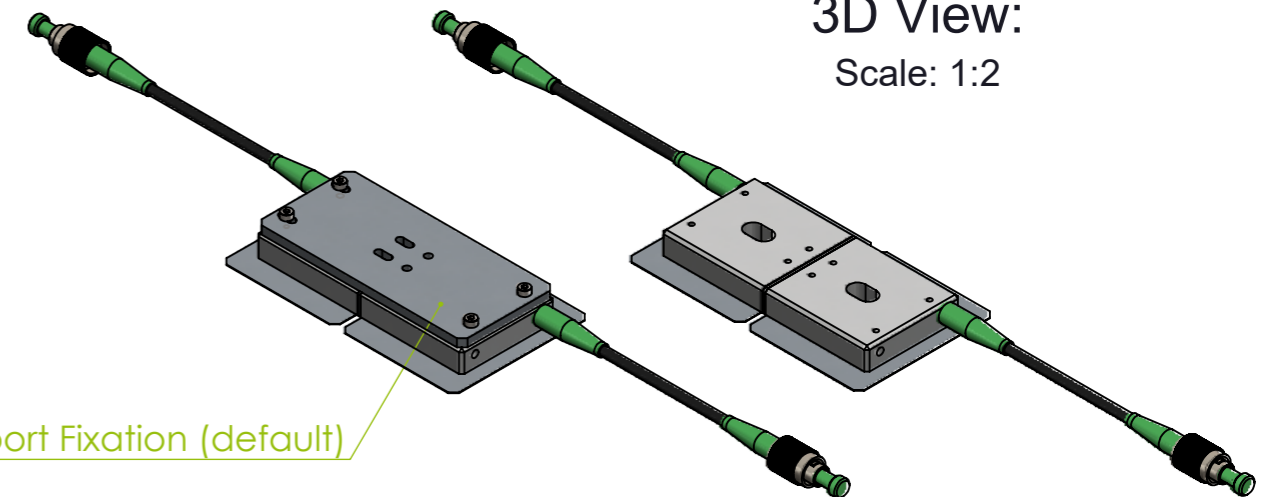
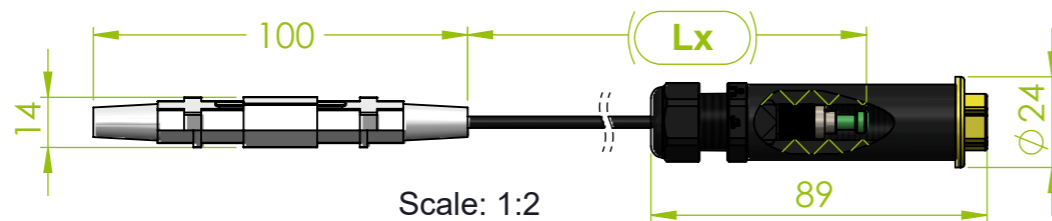

Parameter	Length	Tolerance
L1	1000 mm (standard)	±50 mm
L2	1000 mm (standard)	±50 mm
Lg	30 mm	±2 mm
Lx	Optional: Custom-Defined Length	±xx mm

TITLE: SWS-02 Spot weldable strain sensor			
REVISION: B	SCALE: 1:1	DRAWN BY, DATE:	
	STATUS: In Work	CHECKED BY, DATE: Branislav Pikus 24.03.2021	
	DIMENSIONS IN MM (UNLESS SPECIFIED)	APPROVED BY, DATE: Tomáš Salát 24.03.2021	
NAME OF CAD FILE: SWS-02 WEB		PRODUCT NUMBER: F-SWS-002-xxx-xxx/xx/xxxx	DRAWING NUMBER: SWS-02 WEB
THIS DRAWING CONTAINS INFORMATION THAT IS PROPERTY OF SYLEX s.r.o AND SHOULD NOT BE USED WITHOUT WRITTEN PERMISSION			SHEET No: 1 of 2
			SIZE A3



Twin pigtail version:

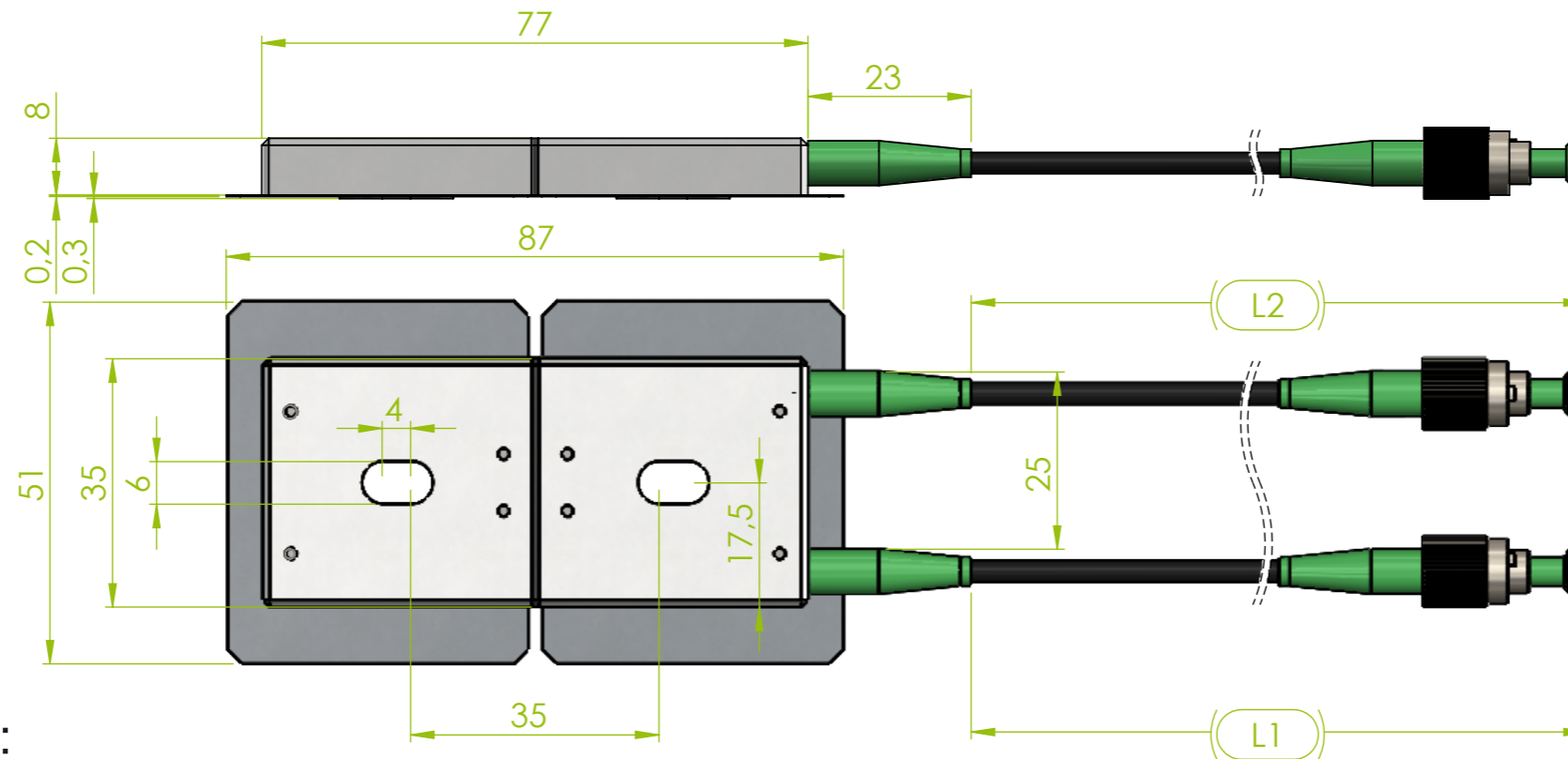

Optional accessories:

- PST-02 Pre-strain setup tool:

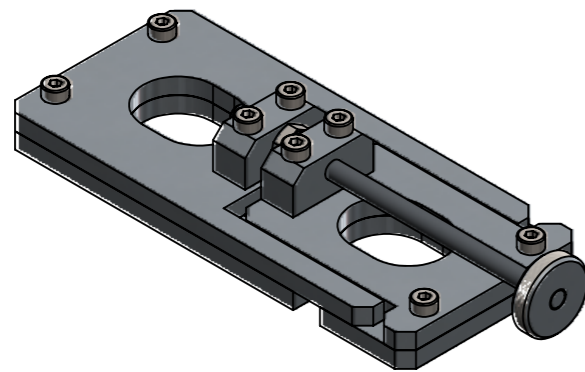

3D View:
Scale: 1:2

Transport Fixation (default)

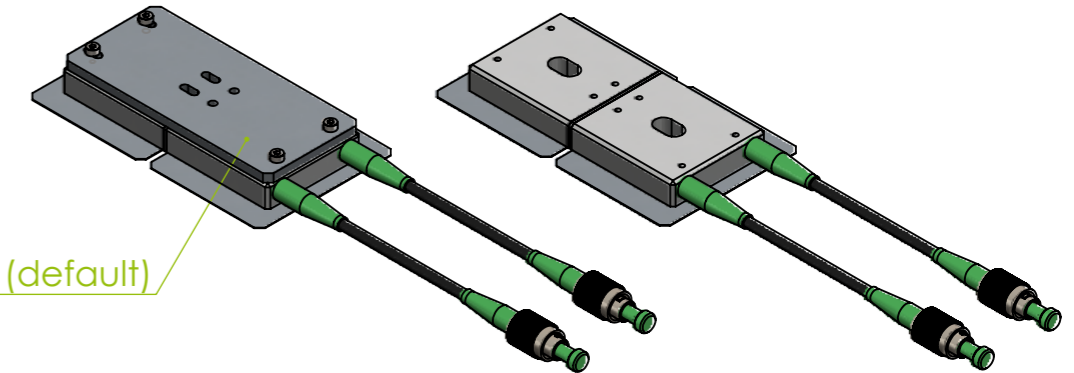

- LCP-03 Longer Dyneema cable pigtail with 1x WSP-02 (Watertight Splice Protection) and with 1x WCP-01 Watertight Connector Protection 1x FC/APC IP67:

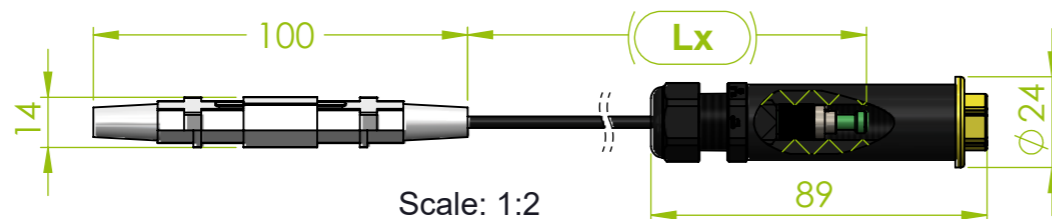

Parameter	Length	Tolerance
L1	1000 mm (standard)	±50 mm
L2	1000 mm (standard)	±50 mm
Lg	30 mm	±2 mm
Lx	Optional: Custom-Defined Length	±xx mm

TITLE: SWS-02 Spot weldable strain sensor			
REVISION: B	SCALE: 1:1	DRAWN BY, DATE:	
	STATUS: In Work	CHECKED BY, DATE: Branislav Pikus 24.03.2021	
	DIMENSIONS IN MM (UNLESS SPECIFIED)	APPROVED BY, DATE: Tomáš Salát 24.03.2021	
NAME OF CAD FILE: SWS-02 WEB		PRODUCT NUMBER: F-SWS-002-xxx-xxx/xx/xxxx	DRAWING NUMBER: SWS-02 WEB
THIS DRAWING CONTAINS INFORMATION THAT IS PROPERTY OF SYLEX s.r.o AND SHOULD NOT BE USED WITHOUT WRITTEN PERMISSION			SHEET No: 2 of 2 SIZE A3

